

## VANDAL PROOF DOME CAMERA

# ZVC-2104A

## 540TVL / CMOS VANDAL PROOF DOME CAMERA



# IP66



### - FEATURES -

- 1/3" CMOS Image Sensor
- 540TV Lines Horizontal Resolution
- Excellent Low Light Sensitivity of 0.1Lux/F1.2
- Auto White Balance
- Auto Gain Control
- Board Lens f=3.6mm
- IP66 Weatherproof Type
- Vandal Proof Dome Housing

**Option :** Wall Mount Bracket



### - DIMENSION -

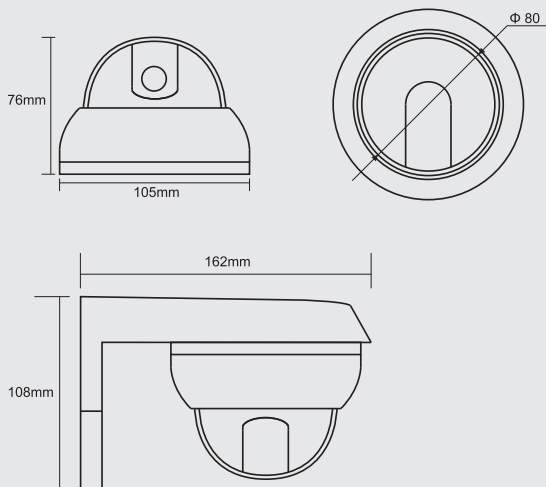

### - WALL MOUNT BRACKET -



MBR-300WM

### - SPECIFICATIONS -

ZVC-2104A	
Signal Format	NTSC / PAL
Horizontal Resolution	540TV Lines
Image Sensor	1/3" CMOS Image Sensor
Total Pixels	762(H) x 504(V)
Effective Pixels	728(H) x 488(V)
Scanning System	2:1 Interlace
Synchronization	Internal
Scanning Frequency	15.734 KHz(H), 59.94 Hz(V)
Video Output	CVBS : 1.0Vp-p/75Ω
Min. Illumination	0.1Lux/F1.2
Iris Control	Auto
Signal to Noise Ratio	More than 48dB
White Balance	Auto
Gain Control	Auto
Lens	Board Lens f=3.6mm
Input Voltage	DC 12V (±10%)
Power Consumption	Max. 0.8W
Operating Temperature	-10°C ~ +50°C
Operating Humidity	30% ~ 90% RH
Dimension	105(Ø) x 76(H)mm
Weight	Approx. 420g